

# CSF706D/S/C

**CHEMISAFE® FIRE 60 UB** TYPE 90 VOLUME 15 LITERS BOTTLES FROM L.

WITHOUT PLINTH **CSF706D/S**

SAFETY CABINET FOR THE STORAGE OF FLAMMABLE PRODUCTS WITH A FIRE RESISTANCE Type90 MINUTES CERTIFIED ACCORDING TO **EN 14470**

## Construction

Completely built in electro galvanized steel sheet with thickness 1 / 1.5 / 2 mm, cold bent with removable external structure painted with acid-proof epoxy powders and passage through a thermal tunnel at 200 ° C

Particular insulation with calcium silicate on panels for high temperature (800 ° C) in high density mineral fiber (without Fibroc ceramic) 300 Kg / m<sup>3</sup> fixed with ceramic adhesives.

Flame retardant melamine laminate panels with high resistance to even aggressive vapors. Certification according to **EN 14470-1** and **EN 16121** standards

## Specifications

- AUTOMATIC door CLOSING in case of temperature > 47 ° C
- LOCK AND LOCK OF DOORS WITH KEY
- Certified automatic closure system (70/100 ° C) of the air inlet and outlet ducts, maintenance-free, located on the back of the cabinet.
- Ejection hole diam. 100 mm. on the back of the wardrobe
- Anti-spark hinge in natural iron with brass pin.
- 3 cm thermo-dilating GASKET. (DIN 4102)
- Bottom tank in PAINTED STEEL WITH SUPPORT GRID. Dim.mm. 383 x 349 x 100 h. (Capacity 13L approximately)
- "Earth" terminal to prevent electrostatic charges.
- WEIGHT 82 Kg
- Dimensions  
External: 595x520x720h mm  
Internal: 483x349x593h mm

## Technical drawing

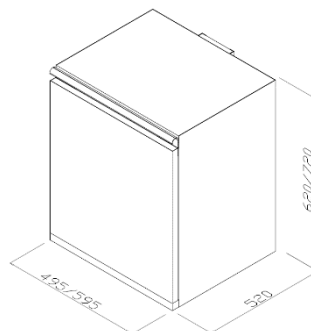

## Image

